

A COMBINE ATTACHMENT THAT
KILLS WEED AND VOLUNTEER
SEEDS WHILE YOU HARVEST



de Bruin
Engineering

Harvest Weed Seed Control
Simpler. Better.

visit ihsd.com



**HARRINGTON SEED
DESTRUCTOR**



HOW IT WORKS.

- ▶ Standing weeds are harvested by the combine
- ▶ Weed seeds or pods are separated into the chaff stream
- ▶ Chaff containing weed seeds is processed by the mills until weed seeds and volunteer seeds are no longer viable
- ▶ Processed chaff and weed seeds are spread back over the field as inert organic material

OPERATIONAL FEATURES.



DIRECT MECHANICAL DRIVE
Less moving parts, more efficient.
Simple.



REAR HATCH ACCESS
For simple grain loss checks



BI-DIRECTIONAL AUGER
To actively feed the mills,
avoiding blockages



STONE TRAP
Avoids foreign objects
entering mills



EASY BYPASS
For windrowing and/or
harvesting without IHSD

SIMPLER. BETTER.

TENSIONING PULLEY

Minimising belt slip

HEAVY DUTY DRIVE BELT

Transmitting torque for power

ADJUSTABLE IDLER PULLEY

Expands to allow chopper
adjustment

IHSD DRIVE PULLEY

Drive pulley maintaining 3000
rpm mill speed, Quick Drive
disengagement clutch

PATENTED IHSD MILLS

2 x vertical mechanical mills
Hardened steel

EXTERNAL CHAFF CHUTE

Direct output below straw to
minimise dust

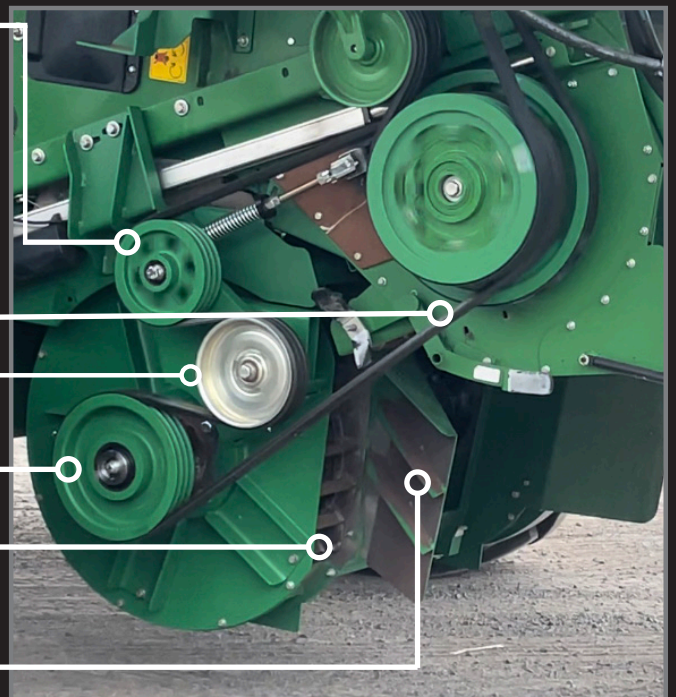



**HARRINGTON SEED
DESTRUCTOR**

JOHN DEERE FEATURES

- ◆ Fits John Deere S-Series S790, S780, S770, S690, S680, S670
- ◆ Supports all factory straw handling systems
- ◆ Active Baffle™ chaff to spreader bypass
- ◆ Quick Drive™ driveshaft dog clutch (optional)
- ◆ Chopper speed selector Slow, High, Neutral
- ◆ Minimal impact installation – no change to jackshaft or pulleys
- ◆ Engage Active Baffle™ and Quick Drive™ to restore JD to standard configuration and harvest performance
- ◆ Quick Off™ belt guards
- ◆ Quick Draw™ removable draw bar and hitch plate (option)
- ◆ Advanced engineering lightweight stiffened auger shaft
- ◆ Cool running low maintenance bearings
- ◆ System can be removed in a few hours and combine restored to factory configuration
- ◆ Configurable mill options – Standard, Heavy Duty™, High Kill™, High Flow™

TRUSTED PARTNER.

- ✓ **DESTROY UP TO 99%**
OF TARGETED WEED SPECIES
- ✓ **ONE PASS HARVEST WEED SEED CONTROL**
NO CHAFF CARTS, NO WINDROWS, NO BURNING
- ✓ **PROVEN**
OVER A DECADE OF COMMERCIALY BUILT HSD AND IHSD PRODUCTS
- ✓ **IMPROVES FUTURE WEED CONTROL**
REDUCES HERBICIDE RESISTANT WEEDS
- ✓ **AUSTRALIAN DESIGNED & BUILT**
25 YEARS OF RESEARCH, DEVELOPMENT, TESTING & REFINEMENT



RAY HARRINGTON.

Western Australian farmer, Ray Harrington, has spent more than 20 years developing methods for harvest weed seed management, the results of which have led to the iHSD.

de Bruin Engineering reserve the right to make changes in engineering or specifications at any time without notice. Although every effort has been made to display accurate information, no responsibility will be taken for any errors contained in this publication.

AVAILABLE TO FIT MODELS:

John Deere		CASE IH			New Holland	
S790	S690	9250	8250	7250	CR 10.90	CR 9090
S780	S680	9240	8240	7240	CR 9.90	CR 8090
S770	S670	9230	8230	7230	CR 8.90	CR 9080
		9120	8120			CR 9070

www.ihsd.com



@SeedDestructor

SIMPLER. BETTER.

Dealer Information: